

Anaerobic Adhesives/Sealants Gasketing

The **TORQUE GASKETING SERIES** allows for maximum clamp loading and positive sealing of mating flanges and housings. These liquid gasketing materials are ideally suited for applications where there are small gaps on rigid metal to metal assemblies. They create a formed in place gasket, eliminating the need for large inventories of pre cut gaskets.

The **TORQUE GASKETING SERIES** keys into the surface of the flanges when they are mated together creating a positive, uniform seal in the joint. This material does not shrink, tear, or relax when fully cured and it is not necessary to re-torque flange bolts when using these products. They are extremely durable materials, that have exceptional pressure and chemical resistance. They are available in a full range of strengths, cure times, and viscosities, to meet specific application requirements.

The **TORQUE GASKETING SERIES** is a total leak prevention system. They are single component, solvent free materials, that fill all the voids, surface gaps, and irregularities, allowing for a positive seal between mating flanges, along with improving the structural integrity of the assembly.

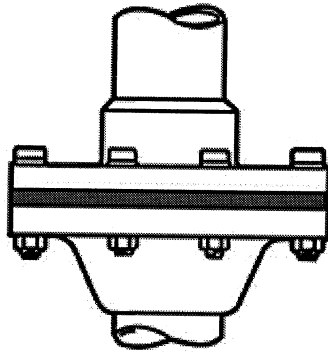

larger image

Results 1 - 9 of 9

<u>Item #</u>	<u>Item Name</u>	<u>Color</u>	<u>Viscosity</u>	<u>Temp. Range</u>	<u>Cure Speed (Fixture)</u>	<u>Cure Speed (Full)</u>	<u>Specific Gravity</u>	<u>MSDS</u>	<u>TDS</u>
<u>TORQUE GM 10</u>	Torque Gasketing Products	Purple	275000 cps	-65 to 350 °F	15 min.	8 hours	1.10	<u>MSDS</u>	<u>TDS</u>
<u>TORQUE GM 20</u>	Torque Gasketing Products	Orange	500000 cps	-65 to 350 °F	30 min.	8 hours	1.08	<u>MSDS</u>	N/A
<u>TORQUE GM 25</u>	Torque Gasketing Products	Red	125000 cps	-65 to 350 °F	5 min.	8 hours	1.20	<u>MSDS</u>	<u>TDS</u>
<u>TORQUE 30</u>	Torque Gasketing Products	Red	800000 cps	-65 to 350 °F	20 min.	8 hours	1.10	<u>MSDS</u>	<u>TDS</u>
<u>TORQUE 35</u>	Torque Gasketing Products	Green	20000 cps	-65 to 350 °F	90 min.	8 hours	1.25	<u>MSDS</u>	<u>TDS</u>
<u>TORQUE GM 40</u>	Torque Gasketing Products	Red	200000 cps	-65 to 450 °F	30 min.	8 hours	1.16	<u>MSDS</u>	<u>TDS</u>
<u>TORQUE 45</u>	Torque Gasketing Products	Blue	100000 cps	-65 to 350 °F	45 min.	8 hours	1.12	<u>MSDS</u>	<u>TDS</u>
<u>TORQUE 50</u>	Torque Gasketing Products	Orange	40000 cps	-65 to 350 °F	5 min.	6 hours	1.11	<u>MSDS</u>	<u>TDS</u>
<u>TORQUE GM 60</u>	Torque Gasketing Products	Blue	Gel	-60 to 600 °F	Instant Seal	Instant Seal	1.09	<u>MSDS</u>	<u>TDS</u>